

**UTILITIES COMMISSION
City of New Smyrna Beach, Florida**

**INVITATION TO BID
CHLORINE CONTACT BASIN AND FLUME COVER
ITB 04-11**

The Utilities Commission, City of New Smyrna Beach (UCNSB) is seeking bids from qualified vendors to fabricate and install permanent covers on an existing chlorine contact basin and flume at the Glencoe Water Treatment Plant.

Notice is hereby given that sealed bids will be received at 200 Canal Street, New Smyrna Beach, FL 32168, until **2:30 p.m., December 17, 2010** at which time they will be opened in the 3rd floor DeBerry room.

SUBMIT BIDS IN DUPLICATE TO: Maureen Lynch, CPPB
Materials Manager
Utilities Commission
City of New Smyrna Beach
(386) 424.3046 Voice
(386) 424.2748 Fax
mlynch@ucnsb.org

MAILING ADDRESS:
Post Office Box 100
New Smyrna Beach, Florida 32170-0100

WALK-IN DELIVERY ADDRESS:
200 Canal Street
New Smyrna Beach, Florida 32168

BIDS DUE BY: **DECEMBER 17, 2010 @ 2:30 PM** after which time they will be publicly opened and read aloud.

Bidders must indicate on the sealed envelope the following:

- A. Invitation to Bid Number**
- B. Hour and Date of Opening**
- C. Name of Bidder**

TABLE OF CONTENTS

<u>DESCRIPTION</u>	<u>PAGE</u>
1. SCHEDULE	3
2. GENERAL TERMS AND CONDITIONS WITH INSURANCE	4-12
3. <u>REQUIRED CERTIFICATIONS AND REPRESENTATIONS</u>	
3.1 CERTIFICATE OF DRUG-FREE WORKPLACE FORM	13
3.2 PUBLIC ENTITY CRIMES FORM	14-15
3.3 STATEMENT FOR NON COLLUSION CERTIFICATION	16
3.4 AUTHORIZED SIGNATURES/NEGOTIATORS	17
3.5 VENDOR INFORMATION	18-19
3.6 QUESTIONNAIRE	20
3.7 REQUIRED DISCLOSURE	21
3.8 BID SUBMITTAL REQUIREMENTS	22-23
4. SCOPE OF WORK	24
SECTION 05140 STRUCTURAL ALUMINUM	25-26
SECTION 05500 MISCELLANEOUS METALS	27-29
SECTION 05520 ALUMINUM RAILINGS	30-32
SECTION 05530 ALUMINUM GRATING SYSTEM	33-35
COMPLETE DRAWINGS	36-39
5. BID FORM	40

SCHEDULE

ITB 04-11

DISTRIBUTION OF THE INVITATION TO BID	NOVEMBER 17, 2010
MANDATORY SITE INSPECTION 10:00AM 2640 PAIGE AVE. NEW SMYRNA BEACH FL, 32168	DECEMBER 7, 2010
DEADLINE FOR FINAL QUESTIONS BY 2:30 PM E-MAIL TO MLYNCH@UCNSB.ORG	DECEMBER 9, 2010
ADDENDUM PUBLISHED BY 5:00PM	DECEMBER 13, 2010
BID RETURN DEADLINE BY 2:30PM LOCATION: UCNSB – RECEPTION 200 CANAL ST. NEW SMYRNA BEACH, FL	DECEMBER 17, 2010

UTILITIES COMMISSION
City of New Smyrna Beach, Florida
GENERAL INSTRUCTIONS AND CONDITIONS

SECTION 2 – GENERAL TERMS AND CONDITIONS

1. The term **COMMISSION** used herein refers to the Utilities Commission, City of New Smyrna Beach, Florida, or its duly authorized representative.
2. The term **BIDDER** used herein refers to the dealer/manufacturer or business organization submitting a bid to the **COMMISSION** in response to this solicitation.
3. **BIDDERS** are expected to examine, when applicable, the drawings, specifications, delivery requirements, performance sites and all instructions to satisfy themselves of conditions affecting cost of performing this contract.
4. No material, labor or facilities will be furnished by the **COMMISSION** unless specifically stated.
5. The **BIDDER** hereby attests that the prices in this offer have been arrived at independently without consultation, communication or agreement with any competitor for the purpose of restricting competition.
6. The **BIDDER** warrants that the prices of the items set forth herein do not exceed the prices charged by the **BIDDER** under a contract with the State of Florida.
7. The **BIDDER** agrees that the supplies and services furnished under this award shall be covered by the most favorable commercial warranties the **BIDDER** gives any customers for comparable quantities of such supplies or services and that the rights and remedies provided herein are in addition to and do not limit any rights afforded to the **COMMISSION** by any other provision of this award.
8. A duly authorized representative of the **COMMISSION** will accomplish inspection and acceptance of the supplies/services purchased herein at the designated delivery point.
9. All invoices resulting from the award of this bid will be paid within 30 days of receipt of invoice or receipt of goods or acceptance of work performed.
10. A Bid Form is provided and a completed original and one duplicate copy shall be returned in a **sealed envelope properly marked with Bid number and acknowledgment of receipt of addenda where applicable.** It is incumbent upon each bidder to ensure that they have received all addenda before submitting their bid.
11. Bids will be publicly opened, read aloud and recorded, on the date and time indicated, at the location specified in the request for bid. It is the Bidders sole responsibility to assure his/her bid is delivered at the proper time and place of the bid. The Commission will not be responsible for late deliveries or delayed mail. Bids delivered after the time specified shall not be considered, such bids shall remain **unopened.**

12. Carelessness in quoting prices or in preparation of bid otherwise, will not relieve the bidder. Bidders are expected to examine specifications, delivery schedule, extensions, and all terms and conditions in the bid documents. Bids having erasures or corrections must be initialed in ink by the Bidder. In the event of an extension error(s), the unit price will prevail. Written amounts shall take precedence over numerical amounts.
13. Bids may be amended or withdrawn only by written notice prior to the bid opening. Amendments must be sealed. Amendments or withdrawals received after the bid opening will not be effective, and the original bid submitted will be considered.
14. **Public Entity Crimes:** UNDER SECTION 287.133(2)(a), FLORIDA STATUTES, A person or affiliate who has been placed on the convicted vendor list following a conviction for a public entity crime may not submit a bid on a contract to provide any goods or services to a public entity, may not submit a bid on a contract with a public entity for the construction or repair of a public building or public work, may not submit bids on leases of real property to a public entity, may not be awarded or perform work as a contractor, supplier, subcontractor, or consultant under a contract with any public entity, and may not transact business with any public entity in excess of the threshold amount provided in Section 287.017, for Category two for a period of 36 months from the date of being placed on the convicted vendor list. See attachment "A".
15. In the event of a tie bid, a preference is given to vendors submitting certification with the bid of
a drug free work place in accordance with Section 287.087 Florida Statutes. This requirement affects all public entities in the State of Florida, and became effective January 1, 1991.
16. Bids shall be **addressed and mailed or delivered as specified on page 1 to 200 Canal St. New Smyrna Beach, Florida 32168.**
17. In the event an Invitation to Bid is returned as a no bid, "**NO BID**" shall be properly marked on the outside of the envelope with the bid number.
18. The **Commission** reserves the right to reject bids containing any additional terms or conditions not specifically requested in the original conditions and specifications.
19. Failure of the contractor to deliver within the time specified, or within a reasonable time as interpreted by the Utilities Commission or failure to make replacements of rejected articles as directed, shall permit the Utilities Commission to purchase on the open market articles of comparable grade to take the place of those rejected or not delivered. On all such purchases, the contractor shall reimburse the **Utilities Commission**, within a reasonable time specified by the Purchasing Authority, for any expenses incurred in excess of the defaulted price. Payments due the contractor by the **Utilities Commission** may be withheld until reimbursement is received.
20. When brand or trade names are used in the bid invitation, it is for the purpose of item identification and to establish standards for quality; style and features. Bids on equivalent items will be considered unless items are noted as no substitutes. Equivalent bids must be accompanied by descriptive literature and/or specifications to receive consideration. Demonstrations and/or samples may be required and shall be at not charge to the Utilities

Commission. The **UTILITIES COMMISSION** reserves the right to determine if bid goods are equivalent to specified goods.

21. Awards shall be made as required for the best interest of the **Commission**. The right is reserved to make award(s) by individual items, group of items, all or none, or any combination thereof, with one or more suppliers.
22. **INDEPENDENT CONTRACTORS**: Contractor is an independent contractor, and all persons employed by Contractor in connection herewith shall be its employees and not employees of Commission in any respect.
23. **INSURANCE**: The Contractor shall, at its sole expense, maintain in effect at all times during the performance of the services insurance coverage with limits not less than those set forth below and with insurers and under forms of policies satisfactory to Commission.

<u>Coverage</u>	<u>Minimum Amounts and Limits</u>
(a) Worker's Compensation	Statutory requirements at location of work
Employer's Liability	\$ 100,000 Each occurrence
	\$ 300,000 Disease, aggregate
	\$ 100,000 Disease, each employee
(b) General Liability	\$1,000,000 General Aggregate
	\$1,000,000 Products – Comp Ops Agg
	\$ 500,000 Each Occurrence
	\$ 50,000 Fire Damage
	\$ 5,000 Medical Expense
(c) Automobile Liability (owned, hired and non-owned)	\$1,000,000 Combined Single Limit
Option of Split Limits:	
(1.) Bodily Injury	\$ 500,000 Per Person
	\$1,000,000 Per Accident
(2.) Property Damage	\$ 500,000

Coverage shall apply to the indemnity agreement and shall include the UTILITIES COMMISSION their officers and employees, each as additional insureds but only as regards to their liability arising out of Contractor's performance of the work or out of operations performed by others on behalf of Contractor under this Contract. The insurance as afforded to such additional insureds shall state that it is primary insurance and shall provide for a severability of interest or cross-liability clause. Prior to commencing performance of any work or site mobilization, Contractor shall furnish Commission with Certificates of Insurance (identifying on the face thereof the Project name and Contract number) as evidence of the above required insurance and such Certificates shall provide for thirty (30) days written notice to Commission prior to cancellation thereof.

Commission is not maintaining any insurance on behalf of Contractor covering loss or damage to the work or to any other property of Contractor unless otherwise specifically set forth herein.

None of the requirements contained herein as to types, limits and approval of insurance coverage to be maintained by Contractor are intended to and shall not in any manner limit or qualify the liabilities and obligations assumed by Contractor under this contract.

Contractor shall deliver the original Certificate of Insurance and one copy to the agent of the Commission.

Notices, in original and one copy, of cancellation, termination and alternation of such policies shall also be provided to the agent of the Commission.

24. **WARRANTY AND ACCEPTANCE:** All material shall be new and workmanship shall be first class in every respect. The work shall be subject to inspection and acceptance by Commission. Contractor guarantees its work hereunder for a period of 12 months after completion and acceptance of the work unless otherwise set forth herein. In the event Commission discovers defects in material or workmanship at any time before the expiration of the specified warranty period, Contractor shall, upon written notice from Commission, repair or replace at its sole expense any such defects. Commission may perform such repairs or replacements by other reasonable means and Contractor agrees to pay for such corrective measures. Neither acceptance of the work by Commission nor payment shall relieve Contractor from liability under the indemnity clause or any of the guarantees or warranties contained or implied herein.
25. **LAWS, REGULATIONS, PERMITS AND TAXES:** Contractor shall comply with Commission's jobsite procedures and regulations and with all applicable local, state and federal laws, rules and regulations and shall obtain all permits required for any of the work performed hereunder. Contractor shall procure and pay for all permits and inspections required for any of the work performed hereunder and shall furnish any bonds, security or deposits required to permit performance of the work. Contractor shall, to the extent permissible under applicable law, comply with the jobsite provisions which validly and lawfully apply to work on the specific jobsite being performed under this Contract.
26. **WORK RULES, SECURITY:** For work performed on Commission premises, Contractor shall strictly observe Commission work rules and security requirements. All work shall be carried out during normal Commission working hours unless specifically agreed to in writing by Commission. Contractor shall, at Commission's request remove from site any employee whom Commission deems to be incompetent, dishonest or uncooperative.
27. **CHANGES:** Commission may, at any time, direct in writing additions, deletions or changes to all or any part of the work. If any such changes causes an increase or decrease in the cost of or in the time required to perform such work, Contractor shall submit detail information substantiating such claims and an equitable adjustment shall be made to the price or time of performance.
28. **RELEASE AGAINST LIENS OR CLAIMS:** Contractor shall promptly pay all claims of persons or firms furnishing labor, equipment or materials used in performing the work hereunder. Commission may require Contractor to submit satisfactory evidence of payment and releases of all such claims. If there is any evidence of any such unpaid claim, the

Utilities Commission may withhold any payment until Contractor has furnished such evidence of payment and release.

29. **ASSIGNMENT:** Any assignment by Contractor of this Contract or of any rights hereunder or hypothecation thereof in any manner, in whole or in part, by operation of law or otherwise, without the prior written consent of the Utilities Commission shall be voided.
30. **SAFETY AND FIRE PREVENTION:** Contractor shall at all times conduct all operations under the Contract in a manner to avoid risks of bodily harm to persons, damage to any property and fire. Contractor shall be responsible to take all precautions necessary and continuously inspect all work, materials and equipment to discover, determine and correct any such conditions which may result in any of the aforementioned risks.
31. **SUSPENSION OF WORK AND TERMINATION:**

Utilities Commission May Suspend Work - The Utilities Commission may at any time and without cause suspend the Work or any portion thereof by notice in writing to the Contractor. The Project Manager shall fix the date on which Work shall be resumed and the Contractor will resume the Work on the date so fixed. The Contractor will be allowed an extension of the Contract Time or both, if directly attributable to any suspension. However, no change to the contract price will be allowed on claims for suspended work or delays, whatever the course or reason. Also, during any period of suspension, the Contractor shall take all available measures to mitigate costs such as taking on new work, reassigning resources to other contracts, etc.

Utilities Commission May Terminate for Cause - If the Contractor is adjudged bankrupt or insolvent; if he makes a general assignment for the benefit of his creditors without Utilities Commission approval; if a trustee or receiver is appointed for the Contractor or for any of his property; if he files a petition to take advantage of any debtor's act or to reorganize under the bankruptcy or similar laws; if he fails to prosecute and complete the Work in accordance with the established Project Schedule or within the Contract Time allowed; if he repeatedly fails to supply sufficient skilled workers or suitable materials or equipment; if he repeatedly fails to make prompt payment to subcontractors for labor, materials or equipment; if he disregards laws, ordinances, rules, regulations or orders of any public body having jurisdiction; if he disregards the authority of the Project Manager; or if he otherwise substantially violates any provisions of the Contract Documents, then the Utilities Commission may, without prejudice to any other right or remedy and after giving the Contractor and his Surety seven (7) days written notice, terminate the services of the Contractor and take possession of the Work and of all materials, equipment, tools, construction equipment and machinery thereon owned by the Contractor and assign the completion of the Work to the Surety, or finish the Work by whatever method it may deem expedient. In such case, the Contractor shall not be entitled to receive any further payment until the Work is finished. If the unpaid balance of the Contract Amount exceeds the direct and indirect cost of completing the Work, including compensation for additional professional services, such excess shall be paid to the Contractor. If such cost exceeds such unpaid balance, the Contractor will pay the difference to the Utilities Commission. Such cost incurred by the Utilities Commission will be determined by the Utilities Commission and incorporated in a Change Order.

Where the Contractor's services have been so terminated by the Utilities Commission, said termination shall not affect any rights of the Utilities Commission against the Contractor then existing or which may thereafter accrue. Any retention or payment of moneys by the Utilities Commission due the Contractor will not release the Contractor from liability.

Upon Termination for Cause, the Contractor shall not be entitled to payment for any anticipated supplemental costs, administrative expenses and/or profit for uncompleted Work - If after notice of termination of the services of the Contractor for cause, it is determined that the Contractor was not in default, the termination shall be deemed to have been for the convenience of the Utilities Commission. In such event the Contractor may recover from the Utilities Commission payment for Work completed and reasonable termination costs as provided in the following paragraph.

Termination for Convenience: Upon seven (7) days written notice to the Contractor and the Surety, or sooner if reasonable under the circumstances, the Utilities Commission may, without cause and without prejudice to any other right or remedy, elect to terminate any part of the Work, or the Contract in whole or in part, as the Utilities Commission may deem appropriate. In any termination for convenience, the Contractor shall be paid for Work completed by the Contractor and subcontractors at the time of termination provided, however, that the payment to the Contractor will exclude any and all anticipated supplemental costs, administrative expenses and profit for uncompleted Work. Upon termination for convenience, the Utilities Commission shall have full power and authority to take possession of the Work, assume any subagreements with Subcontractors and suppliers which the Utilities Commission selects, and prosecute the Work to completion by contract or as the Utilities Commission may deem expedient.

32. **MAINTENANCE OF RECORDS:**

The Contractor will keep adequate records and supporting documents applicable to this contract. Said records and documentation will be retained by the Contractor for a minimum of five (5) years from the date of final payment on this Contract. The Utilities Commission and its authorized agents shall have the right to audit, inspect and copy records and documentation as often as the Utilities Commission deems necessary during the period of this contract and a period of five (5) years after completion of contract performance; provided however, such activity shall be conducted only during normal business hours. The Utilities Commission during the period of time defined by the preceding sentence shall also have the right to obtain a copy of and otherwise inspect any audit made at the direction of the Contractor as concerns the aforesaid records and documentation.

33. **CONFLICT OF INTEREST OF OFFICERS OR EMPLOYEES OF THE CONTRACTING ENTITY/LOCAL JURISDICTION, MEMBERS OF THE LOCAL GOVERNING BODY, OR OTHER ELECTED OFFICIALS:**

No member or employee of the contracting entity/local jurisdiction or its designees or agents; no member of the governing body; and no other public official of the Utilities Commission who exercises any function or responsibility with respect to this contract, during his/her tenure or for one year thereafter, shall have any interest, direct or indirect, in any contract or subcontract, or the proceeds thereof, for work to be performed. Further, the Contractor shall cause to be incorporated in all subcontracts, the language set forth in this paragraph prohibiting conflict of interest.

34. **EMPLOYEE CONFLICT OF INTEREST-** It shall be unethical for any Utilities Commission employee to participate directly or indirectly in a procurement contract when the Utilities Commission employee knows that:

(1) The Utilities Commission employee or any member of the Utilities Commission employee's immediate family has a financial interest in the procurement contract; or

(2) any other person, business, or organization with whom the Utilities Commission employee or any member of a Utilities Commission employee's immediate family is negotiating or has an arrangement concerning prospective employment is involved in the procurement contract.

A Utilities Commission employee or any member of a Utilities Commission employee's immediate family who holds a financial interest in a disclosed blind trust shall not be deemed to have a conflict of interest with regard to matters pertaining to that financial interest.

35. **GRATUITIES AND KICKBACKS:**

(1) Gratuities. It shall be unethical for any person to offer, give, or agree to give any Utilities Commission employee or former Utilities Commission employee, or for any Utilities Commission employee or former Utilities Commission employee to solicit, demand, accept, or agree to accept from another person, a gratuity or an offer of employment in connection with any decision, approval, disapproval, recommendation, or preparation of any part of a program requirement or a purchase request, influencing the content of any specification or procurement standard, rendering of advice, investigation, auditing, or in any other advisory capacity Utilities Commission in any proceeding or application, request for ruling, determination, claim or controversy, or other particular matter, pertaining to any program requirement or a contract or subcontract, or to any solicitation or proposal therefore.

(2) Kickbacks. It shall be unethical for any payment, gratuity, or offer of employment to be made by or on behalf of a subcontractor under a contract to the prime contractor or higher tier sub-contractor or any person associated therewith, as an inducement for the award of a subcontract or order.

Contract Clause. The prohibition against gratuities and kickbacks prescribed in this Section shall be conspicuously set forth in every contract and solicitation therefore.

36. **USE OF PREMISES** - The Contractor will confine his equipment, the storage of materials and equipment, and the operations of his workers to the areas permitted by law, ordinances, permits or the requirements of the Contract Documents and shall not unreasonably encumber the premises with materials or equipment.

The Contractor shall confine the operation of workmen and equipment, and the storage of materials and equipment to the Utilities Commission's property or to other non-Utilities Commission property or in public right-of-way areas indicated on the Contract Drawings as including work to be done pursuant to the Contract documents. In the event the Contractor desires to have access to the project site, or perform work or operations pertaining to the contract on, over or from non-Utilities Commission property adjacent to the project site, the

Contractor shall obtain written authorization to do so from the respective adjacent property owner(s) prior to using such property. Such written authorization shall include a provision whereby the property owner agrees to hold the Utilities Commission harmless, and to defend the Utilities Commission, in the event of any liability, loss, injury, or claim incurred as a result of the Contractors work or operations involving the use of the adjacent non-Utilities Commission property. The Utilities Commission shall be provided with a notarized, certified copy of such written authorization(s) before the Contractor commences work or operations or use of such property in connection with work or operations pursuant to this contract.

37. **EMERGENCIES** - In emergencies affecting the safety of persons, the Work or property at the site or adjacent thereto, the Contractor, without special instruction or authorization from the Project Manager, is obligated to act at his discretion to prevent threatened damage, injury or loss. He will give the Engineer and or Project Manager prompt written notice of any significant changes in the Work or deviations from the Contract Documents caused thereby, and a Change Order shall thereupon be issued covering the changes and deviations involved. If the Contractor believes that additional Work done by him in an emergency which arose from causes beyond his control entitles him to an increase in the Contract Amount or an extension of the Contract Time, he may make a claim.
38. **CHANGES IN THE WORK-** Without invalidating the Agreement, the Utilities Commission may, at any time or from time to time, order additions, deletions or revisions in the Work authorized by written Change Orders or directive. Upon receipt of a Change Order, the Contractor will proceed with the work involved. All such work shall be executed under the applicable conditions of the Contract Documents. If any Change Order causes an increase or decrease in the Contract Amount or any extension or shortening of the Contract Time, an equitable adjustment will be made.

Additional Work performed by the Contractor without authorization of a Change Order will not entitle him to an increase in the Contract Amount or any extension of the Contract Time, except in the case of an emergency.

It is the Contractor's responsibility to notify his Surety of any changes affecting the general scope of the Work or change of the Contract Amount and the amount of the applicable bonds shall be adjusted accordingly, and an amended bond document furnished to the Utilities Commission.

In the event the Utilities Commission directs the Contractor to make a change in the Work, and if the Utilities Commission and the Contractor do not arrive at a mutually acceptable increase or decrease in the Contract Amount, the Contractor shall not use any such lack of mutual acceptance as a basis or cause to stop or otherwise delay the progress or the execution and completion of any of the work ordered, directed or required pursuant to the Contract Documents.

39. **PERFORMANCE AND PAYMENT BONDS-** In the event the Contract is awarded to the Bidder, he will thereafter enter into a written contract with the Owner and furnish a Payment and Performance Bond in an amount equal to the contract price, in strict accordance with Section 255.05 of Florida Statutes. Payment and Performance Bonds shall be secured from

or countersigned by an agency or surety company recognized in good standing and authorized to do business in the State of Florida.

40. **BID BOND**- Bids shall be accompanied by a security deposit as follows. Bid Bond in the amount of a sum no less than 10 percent of the Bid Price/Sum. Endorse the Bid Bond in the name of the Utilities Commission as the obligee, signed and sealed by the principal (Contractor) and surety.

THE UTILITIES COMMISSION RESERVES THE RIGHT TO WAIVE INFORMALITIES IN ANY BID, TO REJECT ANY AND ALL BIDS IN WHOLE OR IN PART, WITH OR WITHOUT CAUSE, AND/OR ACCEPT THE BIDS OR PORTIONS THEREOF THAT IN ITS JUDGMENT WILL BE FOR THE BEST INTEREST OF THE UTILITIES COMMISSION.

SECTION 3 – REQUIRED CERTIFICATIONS AND REPRESENTATIONS

SECTION 3.1

CERTIFICATION OF DRUG-FREE WORKPLACE

IDENTICAL TIE BIDS - Preference shall be given to businesses with drug-free workplace programs. Whenever two or more bids which are equal with respect to price, quality, and service are received by the State or by any political subdivision for the procurement of commodities or contractual services, a bid received from a business that certifies that it has implemented a drug-free workplace program shall be given preference in the award process. Established procedures for processing tie bids will be followed if none of the tied vendors have a drug-free workplace program. In order to have a drug-free workplace program, a business shall:

1. Publish a statement notifying employees that the unlawful manufacture, distribution, dispensing, possession, or use of a controlled substance is prohibited in the workplace and specifying the actions that will be taken against employees for violations of such prohibition.
2. Inform employees about the dangers of drug abuse in the workplace, the business's policy of maintaining a drug-free workplace, any available drug counseling, rehabilitation, and employee assistance programs, and the penalties that may be imposed upon employees for drug abuse violations.
3. Give each employee engaged in providing the commodities or contractual services that are under bid a copy of the statement specified in subsection (1).
4. In the statement specified in subsection (1), notify the employees that, as a condition of working on the commodities or contractual services that are under bid, the employee will abide by the terms of the statement and will notify the employer of any conviction of, or plea of guilty or nolo contendere to, any violation of chapter 893 or of any controlled substance law of the United States or any state, for a violation occurring in the workplace no later than five (5) days after such conviction.
5. Impose a sanction on, or require the satisfactory participation in a drug abuse assistance or rehabilitation program if such is available in the employee's community, by any employee who is so convicted.
6. Make a good faith effort to continue to maintain a drug-free workplace through implementation of this section.

As the person authorized to sign the statement, I certify that this firm complies fully with the above requirements.

VENDOR SIGNATURE

**SWORN STATEMENT UNDER SECTION 287.133(3) (1)
FLORIDA STATUTES, ON PUBLIC ENTITY CRIMES**

THIS FORM MUST BE SIGNED IN THE PRESENCE OF A NOTARY PUBLIC OR OTHER OFFICER AUTHORIZED TO ADMINISTER OATHS.

1. This sworn statement is submitted Bid, Bid or Contract for_____.

2. This sworn statement is submitted by_____

[name of entity submitting sworn statement] whose business address is: _____

_____and (if applicable) its Federal Employer

Identification Number (FEIN) is _____.

(If entity has no FEIN, include the Social Security Number of the individual signing this sworn statement:

_____.

3. My name is _____and my relationship to the entity named above is _____.

4. I understand that a "public entity crime" as defined in Paragraph 287.133 (1) (g), Florida Statutes, means a violation of any state or federal law be a person with respect to and directly related to the transaction of business with any public entity or with an agency or political subdivision of any other state or with the United States, including, but not limited to, any bid or contract for goods or services to be provided to any public entity or an agency or political subdivision of any other state, or of the United States and involving antitrust, fraud, theft, bribery, collusion, racketeering, conspiracy, or material misrepresentation.

5. I understand that "convicted" or "conviction" as defined in Paragraph 287.133 (91) (b), Florida Statutes means a finding of guilt or a conviction of a public entity crime, with or without adjudication of guilt, in any federal or state trial court or recording, relating to charges brought by federal or state trial court or recording, relating to charges brought by federal or state trial court or recording, relating to charged brought by indictment or information after July 1, 1989, as a result of just verdict, non-jury trial, or entity of a plea of guilty or nolo contendere.

6. I understand the "affiliate" as defined in Paragraph 287.133(1)(a), Florida Statutes, means: (1) A Predecessor or Successor of a person convicted of public crime: or (2) An entity under the control of any natural person who is active in the management of the entity and who has been convicted of a public entity crime. The term "affiliate" includes those officers, directors, executives, partners, shareholder, employees, members, and agents who are active in the management of an affiliate. The ownership by one person of shares constituting a controlling interest in another person, or a pooling of equipment or income among persons when not for fair market value under an arm's length agreement, shall be a prima facie case that one person controls another person. A person who knowingly enters into a joint venture with a person who has been convicted of public crime in Florida during the preceding 36 months shall be considered an affiliate.

7. I understand that a "person" as defined in Paragraph 287.133(1) (e), Florida Statutes, means any natural person or entity organized under the laws of any state or of the United States with the legal power to enter into a binding contract and which bids or applies to bid on contracts for the provisions of goods or services let by a public entity, or which otherwise transacts or applies to transact business with a public entity. The term "person" includes those officers, directors, executives, partners, shareholders, employees, members and agents who are active in management of an entity.

8. Based on information and belief, that statement which I have marked below is true in relation to the entity submitting this sworn statement. [Please indicate which statement applies]

Public Entity Crimes Statement

Page 2 of 2

_____ Neither the entity submitting this sworn statement, or one more of the officers, directors, executives, partners, shareholders, employees, members or agents who are active in the management of the entity, nor any affiliate or the entity, has been charged with and convicted of public entity subsequent to July 1, 1989, AND [Please indicate which additional statement applies.]

_____ There has been a proceeding concerning the conviction before a hearing officer of the State of Florida, Division of Administrative Hearings. The final order entered by the hearing officer did not place the person or affiliate on the convicted vendor list. [Please attach a copy of the final order.]

_____ The person or affiliate was placed on the convicted vendor list. There has been a subsequent proceeding before a hearing officer of the State of Florida, Division of Administrative Hearings. The final order entered by the hearing officer determined that it was in the public interest to remove the person or affiliate from the convicted vendor list. [Please attach a copy of the final order.]

_____ The person or affiliate has not been placed on the convicted vendor list. [Please describe any action taken by or pending with the Department of General Services.]

_____ Date _____ Signature _____

STATE OF: _____

COUNTY OF: _____

PERSONALLY APPEARED BEFORE ME, the undersigned authority,

_____ [name of individual signing] who after first sworn by me affixed his/her signature in the space provided above on this _____ day of _____, 20_____.

My commission expires: _____
Notary Public

Print, Type, or Stamp of Notary Public

Personally known to me, or
Produced Identification:

Type of I.D.

NON-COLLUSION AFFIDAVIT OF PRIME BIDDER

State of _____

County of _____

_____, being first duly sworn, deposes and says that:

He/she is _____ of _____, Bidder that has submitted the attached Bid;

He/she is fully informed respecting the preparation and contents of the attached Bid and of all pertinent circumstances respecting such Bid;

Neither the said Bidder nor any of its officers, partners, owners, agent representatives, employees, or parties in interest, including this affiant, has in any way colluded, conspired, connived or agreed, directly or indirectly, sought by agreement or collusion or communication or conference with any other Bidder, firm or person, to fix the price or prices in the attached Bid or of any other Bidder, or to fix any overhead, profit or cost element of the Bid price or the Bid price of any other Bidder, or to secure through any collusion, conspiracy, connivance or unlawful agreement any advantage against the UCNSB.

The price or prices quoted in the attached Bid are fair and proper and are not tainted by any collusion, conspiracy, connivance or unlawful agreement on the part of the Bidder or any of its agents, representatives, owners, employees, or parties in interest, including this affiant.

Signed

Title

Subscribed and sworn to before me this ____ day of _____, 20__.

Title

My Commission Expires: _____

SECTION 3.4 - AUTHORIZED SIGNATURES/NEGOTIATORS

The bidder or proposer represents that the following persons are authorized to sign and/or negotiate contracts and related documents to which the bidder or proposer will be duly bound:

Name	Title	Phone #
_____	_____	_____
_____	_____	_____
_____	_____	_____
_____	_____	_____

(Signature)

(Title)

(Name of Business)

The bidder/offeror shall complete and submit the following information with the bid or proposal:

Type of Organization

_____ Sole Proprietorship _____ Partnership

_____ Joint Venture _____ Corporation

State of Incorporation: _____

Federal I.D. or Social Security number is: _____

SECTION 3.5

VENDOR INFORMATION

In addition to General conditions, your BID may be disqualified if the following vendor information is not returned with your BID.

Vendor is:

- () Corporation
- () Partnership
- () Sole Proprietorship
- () Other _____(Explain)

Federal Employer Identification

Number or Social Security Number: _____

Do you collect Florida State Sales Tax? () Yes () No

Firm Name: _____

Mailing Address: _____

Telephone No. _____ Fax No. _____

Email Address: _____ Web Address: _____

Commodity or Service Supply: _____

If vendor is quoting, as a manufacturer's representative and the purchase order should be addressed to the manufacturer in care of the vendor, so indicate.

If remittance address is different from the mailing address so indicate below.

Firm Name: _____

Mailing Address: _____

Submitted by: _____

Name & Title Printed: _____

REQUEST FOR TAXPAYER IDENTIFICATION NUMBER

Step 1. Provide your complete name and Taxpayer Identification Number (Check ONE box only)

U.S. Resident – Individual/Sole Proprietor (Form 1099 reportable)

Name _____

If you are a sole proprietor, name the owner of the business: _____

Social Security Employer

Number _____--____--____ Identification Number _____--____--____

U.S. Partnership, Limited Liability Company (“LLC”), or Trust (Form 1099 reportable)

Name (as shown on your tax return) _____

Employer

Identification Number _____--____--____

U.S. Corporation (exempt from Form 1099 reporting except for medical or legal services)

(If an LLC electing corporate status for U.S. tax purposes, please attach a copy of your U.S. tax election on IRS Form 8832, *Entity Classification Election*)

Name (as shown on your tax return) _____

Employer

Identification Number _____--____--____

U.S. Tax-Exempt Organization or Federal, State, or Local Government Agency (exempt from Form 1099 reporting)

Name (as shown on your tax return) _____

Employer

Identification Number _____--____--____

Step 2. Certification/Signature (Complete the following) Under penalties of perjury my signature certifies that:

1. The number shown on this form is my correct taxpayer identification number (or I am waiting for a number to be issued to me).
2. I am not subject to backup withholding because: (a) I am exempt from backup withholding, or (b) I have not been notified by the Internal Revenue Service (IRS) that I am subject to backup withholding as a result of a failure to report all interest or dividends, or (c) the IRS has notified me that I am no longer subject to backup withholding.
3. I am a U.S. person* (including a U.S. resident alien).

Certification Instructions - You must cross out item 2 above if you have been notified by the IRS that you are currently subject to backup withholding because you have failed to report all interest and dividends on your tax return. For real estate transactions, number 2 above does not apply. For mortgage interest paid, acquisition or abandonment of secured property, cancellation of debt, contributions to an individual retirement arrangement (IRA), and generally, payments other than interest and dividends, you are not required to sign the Certification, but you must provide your correct TIN.

Signature: _____ Phone: (____) _____

Print Name: _____ Title: _____ Date: _____

Address: _____ City: _____ State: _____ ZIP: _____

Instructions for U.S. Tax Persons

As a business, federal income tax law requires us to report certain payments we make to you if you are not exempted from this reporting responsibility. In order for us to properly meet the federal tax law requirements, we need certain information from you. Please complete the information requested above and return this form to the address shown above. If you do not provide us with your correct taxpayer identification number, you may be subject to a \$50 penalty imposed by the Internal Revenue Service. In addition, you may be subject to 28% backup withholding on reportable payments we make to you.

If you have any questions, please call us at _____ (provide requester's telephone number).

***Are you a U.S. person?** The IRS defines a U.S. person as:

- a U.S. citizen;
- an entity (company, corporation, trust, partnership, estate, etc.) created or organized in, or under the laws of, the United States; a state; or the District of Columbia;
- a U.S. resident alien (someone who has a “green card” or has passed the IRS “substantial-presence test.”)

For an explanation of the substantial-presence test, please see IRS Pub. 515 or 519, available at www.irs.gov.)

If your answer is NO, please do not complete this form and contact us at (insert requester's phone number here) _____.

If your answer is YES, please complete the form.

See page 2 for additional information.

FOR OFFICE USE ONLY

Please complete and return to: (requester's return address)

(Requester enters name, address, and account as they appear in requester's records.)

Name _____

Locator ID _____

SECTION 3.6

QUESTIONNAIRE ITB # 04-11

Additional space may be required. Please answer questions in the order presented. All questions must be answered or contractor may be disqualified.

1. Has your company ever been denied insurance or had insurance canceled?
2. Is your company bondable? Has your company ever been denied bond? If yes, explain.
3. Can your insurance company produce a certificate of insurance stating your limits and naming UCNSB as an Additional Insured?
4. Since January 1, 2001, has your company been a defendant in any lawsuits?
5. Is your company a subsidiary or otherwise legally affiliated with any other company?
6. Is your company rated by Dunn & Bradstreet or any other rating agency? If yes, what is the name of the agency and rating?
7. Is your company in any stage of bankruptcy, including initial filing?
8. Can you supply us with three (3) business references similar to UCNSB? If yes, attach a list including contact and phone number.
9. Has your company been disbarred by the Federal Government or any State Government?
10. How many employees does your company have?

Staff Employees: Full Time_____ Part Time_____

Contract Employees: Full Time_____ PartTime_____

SECTION 3.7

REQUIRED DISCLOSURE

At its sole discretion, the Owner may reject any bidder the Owner finds to lack, or whose present or former executive employees, officers, directors, stockholders, partners or owners are found by the Owner to lack honesty, integrity, or moral responsibility. The discretion of the Owner may be exercised based on the Owner's own investigation, public records, or any other reliable sources of information. By submitting a bid, bidder recognizes and accepts that the Owner may reject the bid based upon the exercise of its sole discretion and bidder waives any claim it might have for damages or other relief resulting from the rejection of its bid based on these grounds.

THE UTILITIES COMMISSION RESERVES THE RIGHT TO WAIVE INFORMALITIES IN ANY BID, TO REJECT ANY AND ALL BIDS IN WHOLE OR IN PART, WITH OR WITHOUT CAUSE, AND/OR ACCEPT THE BIDS OR PORTIONS THEREOF THAT IN IT'S JUDGMENT WILL BE FOR THE BEST INTEREST OF THE UTILITIES COMMISSION.

SECTION 3.8

BID SUBMITTAL REQUIREMENTS

Bids shall include all of the information solicited in this ITB, and any additional information that the Bidder deems pertinent to the understanding and evaluating of the bid. Bids shall be organized and sections tabbed in the following order. The Bidder should not withhold any information from the written response in anticipation of presenting the information orally or in a demonstration, since oral presentations or demonstrations may not be solicited. All bids shall include, at a minimum, the following information. Failure to supply all of the information requested may result in the bid being excluded from consideration.

Factor #1 **Experience:**

Provide a profile showing company history, business structure, list of principals. A minimum of five (5) years in business is required.

Factor #2 **References:**

Submit a detailed list of clients receiving similar services within the last two years. Please include a brief description of the scope of work performed and the name, phone number and email address of the contact person.

Factor #3 **Pricing:**

Submit Bid Reply Sheet here

Factor #4 **License and Insurance:**

Include a copy of your current Occupational License from an authorizing government agency. Submit a copy of your Certificate of Insurance here. UCNSB does not need to be named as an Additional Insured at this time but that is a requirement when work commences.

Factor #5 **Public Entity Crimes and Non-collusion Affidavit**

All Bidders shall properly complete, notarize and submit Public Entity Crimes Non Collusion Form included in this document.

Factor #6 **Addenda Acknowledgement**

Please submit all addenda (if any) related to this bid here.

Factor #7 **Questionnaire**

The Questionnaire responses requested in Section 3.6 should be submitted here

Factor #8 **Vendor Application**

Submit completed vendor application here

Factor #9 **Other Information**

Provide any information / samples that will provide insight to the evaluators about the qualifications, fitness and abilities of the Bidder. This information should be succinct.

SECTION 4 SPECIFICATIONS/SCOPE OF WORK

The UCNSB Glencoe Water Treatment Plant seeks to have permanent covers installed on it's existing chlorine contact basin and flume so that the Volusia County Department of Health can approve the Plant for Log 4 Virus Treatment for Finished Water per EPA's Ground Water Rule.

This project requires fabrication and installation of structural supports to hold grating and diamond plating for the existing basin and flume. This project also includes the installation of hand rails and kick plates around the existing basin.

Attached are 100% plans and specifications approved by the UCNSB's Engineering Department and serve as the official bid documents. This is a turnkey project.

The Contractor will be responsible for getting a building permit from Volusia County.

The Contractor will be responsible for temporary water and electric required to complete the project.

The UCNSB will obtain the Volusia County Department of Health permit.

The UCNSB requests that all potential bidders be present at a mandatory on-site pre-bid meeting to be held Tuesday, December 7, 2010 at 10AM. Any questions/comments shall be presented at this meeting.

The UCNSB requires that this project be completed in 60 days or less.

The UCNSB will issue 2 partial payments:

- After all fabricated parts are delivered on site and accounted for by a UC representative.
- After Certificate of Occupancy (C.O.) is issued by Volusia County and DOH Clearance is obtained.

Bids shall be accompanied by a security deposit as follows. Bid Bond in the amount of a sum no less than 10 percent of the Bid Price/Sum. Endorse the Bid Bond in the name of the Utilities Commission as the obligee, signed and sealed by the principal (Contractor) and surety.

SECTION 05140

STRUCTURAL ALUMINUM

PART 1 - GENERAL

1.01 WORK INCLUDED

- A. Scope of Work: The work under this Section includes fabrication and erection of structural aluminum.

1.02 QUALITY ASSURANCE

- A. Qualifications: Fabrication and erection shall be by a qualified fabricator and erector approved by the Engineer. Preparation of Shop Drawings shall not begin until the fabricator and erector have been approved.
- B. Standards: Unless otherwise specified, all materials, workmanship and practices shall conform to the current editions of the following Standards:

- 1. Florida Building Code.**

- 2. Aluminum Construction Manual, latest edition by the Aluminum Association.
 - 3. OSHA Standards.

1.03 SUBMITTALS

- A. Complete Shop Drawings, including material lists, fabrication and erection drawings shall be submitted for approval in accordance with Section 01340. Fabrication shall not be approved until the submission has been approved.

PART 2 - PRODUCTS

2.01 MATERIALS

- A. Standard Shapes, Bars & Plates:
 - 1. ASTM B 209 - Alloy 6061-T6.
 - 2. ASTM B 308 - Alloy 6061-T6.

- B. Aluminum Fasteners: Connections of aluminum to aluminum shall be of aluminum. Bolts shall meet the requirements of ASTM B316 for alloy 2024-T4. Bolts shall have an anodic coating having a minimum thickness of .0002 inches. Nuts shall be 6061-T6. Washers shall be Alclad 2024-T4.
- C. Stainless Steel Fastenings: Connections of aluminum to stainless steel or concrete shall be stainless steel bolts of AISI Type 316.

2.02 FABRICATION

- A. Fabrication shall be in accordance with the specified standards. Size of various members and number or parts indicated on the drawings are minimum and shall be increased as necessary to meet requirements. Stairs shall comply with OSHA standards. Splices not indicated on the Drawings will not be permitted.
- B. Surface Treatment: Treatment is required only if indicated on the Drawings.

PART 3 - EXECUTION

3.01 ERECTION

- A. Erection shall be in accordance with the specified standards and as indicated on the Drawings.
- B. Where the contact of dissimilar metals may cause electrolysis or where aluminum will contact concrete, mortar or plaster, the contact surface of the metals shall be coated with a bituminous coating.**

END OF SECTION

SECTION 05500

MISCELLANEOUS METALS

PART 1 - GENERAL

1.01 WORK INCLUDED

- A. Scope of Work: This Section covers the use of miscellaneous metals, shapes and sheets, fittings, fasteners, wirework, Contractor fabricated pipe supports, etc., not specified elsewhere in these Specifications.

1.02 QUALITY ASSURANCE

- A. Standards: Unless otherwise specified, all materials, workmanship and practices shall conform to the current editions of the BOCA Building Code, OSHA Standards, AISC Specifications for the Design, Fabrication and Erection of Structural Steel for Buildings, Code of Standard Practice, American Welding Society Code AWS D1.1, Aluminum Construction Manual and the other Standards referenced in this Section.

PART 2 - PRODUCTS

2.01 MATERIALS

- A. Steel: Miscellaneous steel plates, shapes, bars and connections shall conform to the requirements of ASTM Designation A 36 and shall be galvanized by the hot dip method after fabrication in accordance with the requirements of ASTM Designation A 123. Steel shall comply with the provisions of Section 05120.
- B. Steel Pipe: Steel pipe used for miscellaneous members and connections shall conform to the requirements of ASTM Designation A 53, Schedule 40, galvanized except as otherwise indicated.
- C. Anchor Bolts and Fasteners:
 - 1. Anchor bolts securing equipment or any assemblies subject to vibrations or movements, shall be stainless steel hook anchors conforming to ANSI 316 and ASTM A193 grade B8M, unless otherwise noted. Hook anchors shall be to the farthest layer of reinforcing. The minimum length protruding for the face of concrete shall be 6 inches and the minimum length of hook shall be 6 inches. All dimensions and sizes of anchor bolt shall comply with manufacturer's recommendations.

2. Anchor bolts and fasteners not securing equipment or assemblies subject to vibration shall be stainless steel wedge or adhesive anchors conforming to ASNI 316 and ASTM A193 grade B8M, unless otherwise noted. Wedge anchors shall be as manufactured by "HILTI" or equal. Adhesive anchors shall consist of a self-contained vinyl ester adhesive cartridge and anchor rods. Adhesive anchor shall be AVA adhesive anchoring system as manufactured by "HILTI", or equal.
- D. Welding Electrodes: Welding electrodes for structural steel shall conform to AWS A5.5, E70XX. Use 4043 filler metal for aluminum. Use type E308 electrode where the base metal is type 304 stainless steel and type E309 where the base metal is type 316 stainless steel or where stainless steel is welded to carbon steel. Field welding of galvanized steel shall not be acceptable.
 - E. Castings: Castings for manhole frames, covers and other items shall conform to the requirements of ASTM Designation A 48, Class 30 and the details shown on the drawings. Castings shall be true to pattern in form and dimensions and free of blow holes, cracks and other pouring faults and defects. The seating surfaces between frames and covers shall be machined to fit true as not to rock or rattle. Lifting or "pick" holes shall be provided, but shall not penetrate through the cover. No plugging or filling will be allowed. If the area is subject to flooding, the castings shall be of a waterproof design with rubber gasket and stainless steel bolts to fasten lid to frame.
 - F. Aluminum Stairs: Aluminum stairs shall be as indicated on the Drawings. Stairs shall be connected to the appropriate structural members. Stair members shall be constructed to support dead loads and additional live working stresses permitted for materials in BOCA Building Code. Size of various members and number of parts indicated on the Drawings are minimum, and shall be increased as necessary to meet requirements. Stairs shall comply with OSHA Standards.
 - G. Aluminum Stair Treads: Aluminum stair treads shall be of the same pattern and alloys as the aluminum grating and shall have a 1 inch wide abrasive nosing. Aluminum bars shall have a standard mill finish.
 - H. Miscellaneous Aluminum: Miscellaneous aluminum shapes, bars and plates shall be Alloy 6061-T6, except when otherwise specified.

2.02 FABRICATION

- A. Insofar as possible, fabricated material shall be fitted and shop assembled ready for erection. Welding and equipment shall conform to American Welding Society's Code for Welding in Building Construction, latest edition. All work shall be square, plumb and true, accurately fitted with tight joints and intersections. Exposed work shall be finished smooth with welds ground smooth.

B. Painting and Protective Coating:

1. All ferrous metal, except stainless steel and galvanized surfaces, shall be properly cleaned and given one shop coat of the fabricator's standard primer. Anchors that are built into masonry shall be coated with asphalt paint unless specified to be galvanized. Metal work to be encased in structural concrete shall be left unpainted unless specified or noted otherwise.
2. Hot-dip galvanizing or zinc coatings applied on products fabricated from rolled, pressed or forged steel shapes, plates, bars and strips shall comply with ASTM Designation A 123. Hot-dip galvanizing or zinc coatings on assembled steel products shall comply with ASTM Designation A 386. The weight of coatings shall be designated in Table 1 for the class and thickness of material to be coated. Galvanized surfaces for which a shop coat of paint is specified shall be chemically treated to provide a bond for the paint. Except for bolts and nuts, all galvanizing shall be done after fabrication.

PART 3 - EXECUTION

3.01 ERECTION

- A. Where the contact of dissimilar metals may cause electrolysis and where aluminum will contact concrete, mortar or plaster, the contact surface of the metals shall be coated in accordance with Section 09900.
- B. All work shall be adequately anchored in place a proper elevations, planes and locations.

END OF SECTION

SECTION 05520

ALUMINUM RAILINGS

PART 1 - GENERAL

1.01 WORK INCLUDED

- A. Scope of Work: The work under this section includes fabrication and erection of aluminum railings.

1.02 QUALITY ASSURANCE

- A. Standards: Unless otherwise specified, all materials, workmanship and practices shall conform to the following standards:
 - 1. 2007 Building Code with 2009 Amendments
 - 2. Occupational Safety and Health Administration Standards.

1.03 SUBMITTALS

- A. Shop Drawings and calculations for aluminum railings shall be submitted for approval in accordance with Section 01340 prior to fabrication of these items. All drawings and calculations shall bear the seal of a Professional Engineer registered in the State of Florida.

PART 2 - PRODUCTS

2.01 MATERIALS

- A. The aluminum railing shall be 1 1/2" inch diameter minimum nominal size aluminum pipe, (O.D.1.90 inch) alloy 6063-T6 or Alcoa alloy 6063-T832. Brackets shall be cast aluminum alloy B214. Floor flanges shall be forged aluminum, alloy 6061-T6. Brackets and flanges shall be secured to aluminum framing members with aluminum fasteners. Railings shall be fabricated in shop, made and erected square, plumb, straight and true, designed for adjustment to field variations, accurately fitted with tight joints and intersections. Fittings shall be fastened to pipe members by either inert gas shielded metal arc welding methods as per Alcoa's Welding Alcoa Aluminum, latest edition, or by internal, mechanical, self-tapping screws, combined with a stainless steel, blind, rivet-locking component fastener system. Finish shall be 1 hour anodized -#215R1. Complete railings shall conform to OSHA Standards, BOCA Building Code and Aluminum Construction Manual by the Aluminum Association.

- B. Kickplates: Aluminum kickplates where not specifically called for in the Drawings shall be furnished and installed typically at the edges of all walkways and landings. Kickplates shall be 1/4 inch plate stock (depending on the specific walkway edge detail) meeting OSHA and Standard Building Code requirements and shall project 4 inches above walkway surface. Kickplates shall not infringe on minimum required walkway width and material must be same as that of the railing construction.

2.02 FABRICATION

- A. Insofar as possible, fabricated material shall be fitted and shop assembled ready for erection. Welding and equipment shall conform to American Welding Society's Code for Welding in Building Construction, latest edition. All work shall be square, plumb and true, accurately fitted with tight joints and intersections. Exposed work shall be finished smooth with welds ground smooth.

PART 3 - EXECUTION

3.01 HANDRAILS

- A. Handrails and stair rails shall be designed to withstand a 200# concentrated load applied in any direction at any point on the top rail. Handrails and stair rails shall also be designed to withstand a load of 50#/ft applied horizontally to the top rail. The 200# load will not be applied simultaneously with the 50#/ft load. In addition, the handrails shall be designed to withstand a load of 100#/ft applied vertically downward to the top rail and simultaneously with the 50#/ft horizontal load. The 100#/ft vertical load does not apply to stair rails.
- B. The manufacturer shall submit calculations to the Engineer for approval. Testing of base castings or base extrusions by an independent lab or manufacturer's lab (if manufacturer's lab meets the requirements of the Aluminum Association) will be an acceptable substitute for calculations. Calculations will be required for approval of all other design aspects.

3.02 POST SPACING

- A. Post spacing shall be a maximum of 6'-0". Posts and railings shall be a minimum of 1 1/2" Schedule 40 aluminum pipe alloy 6063-T6, ASTM B429 or ASTM B221. The handrail manufacturer shall show that their posts are of adequate strength to meet the loading requirements. If the manufacturer's posts are not of adequate strength, the manufacturer may reduce the post spacing or add reinforcing dowels or may do both in order to meet loading requirements.

3.03 COMPONENTS

- A. The handrail shall be made of pipes joined together with component fittings. Samples of all components, bases, toe plate and pipe must be submitted for approval. Components that are pop-riveted or glued at the joints will not be acceptable. All components must be mechanically fastened with stainless steel hardware.

3.04 POSTS

- A. Posts shall not interrupt the continuation of the top rail at any point along the railing, including corners and end terminations (OSHA 1910.23). The top surface of the top railing shall be smooth and shall not be interrupted by projecting fittings.

3.05 MIDRAIL

- A. The midrail at a corner return shall be able to withstand a 200# load without loosening. The manufacturer is to determine this dimension for their system. Provide physical tests from a laboratory to confirm compliance.

3.06 TOE PLATE

- A. Toe plate shall conform to OSHA standards. Toe plate shall be a minimum of 4" high and shall be an extrusion that attaches to the posts with clamps which will allow for expansion and contraction between posts. Toe plates shall be set 3" above the walking surface. Toe plates shall be provided on handrails as required by OSHA and/or as shown on drawings. Toe plates shall be shipped loose in stock lengths with premanufactured corners for field installation.

3.07 OPENINGS

- A. Openings in the railing shall be guarded by a self-closing gate (OSHA 1910.23). Safety chains shall not be used unless specially shown on the drawings.

3.08 ALUMINUM SURFACES

- A. Aluminum surfaces in contact with concrete, grout or dissimilar metals will be protected with a coat of bituminous paint, mylar isolators or other approved material.

END OF SECTION

SECTION 05530

ALUMINUM GRATING SYSTEM

PART 1 - GENERAL

1.01 WORK INCLUDED

- A. Scope of Work: Furnish all labor, materials, and incidentals required to install the aluminum grating, the structural members supporting the grating and the angles, connections, fastenings and concrete inserts attached to or supporting the grating, or those structural members as shown on the drawings, or specified herein.

1.02 QUALITY ASSURANCE

- A. Standards: Unless otherwise specified, all materials, workmanship and practices shall conform to the current editions of the following standards:
 - 1. Metal Bar Grating Manual, latest edition of the National Association of Architectural Metal Manufacturers.
 - 2. Aluminum Construction Manual, latest edition of the Aluminum Association.

1.03 SUBMITTALS

- A. Complete fabrication and erection drawings showing all components of the aluminum grating system shall be submitted. Fabrication shall not begin until Engineer's review is complete.

PART 2 - PRODUCTS

2.01 ALUMINUM GRATING

- A. Configuration: Grating shall be pressure locked aluminum having rectangular or I shaped bearing bars spaced at 1-3/16 inches on centers and sized as indicated on the Drawings. Cross bars shall be spaced at 4 inches on centers. All grating surfaces shall be "slip-resistant" serrated type. Limit the weight of single pieces of grating to not more than 80 pounds. Individual pieces shall not be of less length than one and one-half times the width, unless limited by the installation.
- B. Material: Bearing bars shall be of extruded aluminum meeting all requirements of ASTM B221-76, alloy 6061-T6 or 6063-T6. Cross bars shall be drawn or extruded aluminum meeting all requirements of ASTM B210-76 or B221-76. Bearing bars shall be minimum 12 inches deep.

- C. Anchors shall be aluminum saddle clips. Each individual grate shall have no less than four saddle clips.
- D. Fabrication shall meet all requirements of the NAAMM Metal Bar Grating Manual. Finish shall be mill finish.

2.02 ALUMINUM SHAPES

- A. Configuration: Shapes shall be as indicated on the Drawings and as detailed in Section 3 of the Aluminum Construction Manual.
- B. Material: Shapes shall meet all requirements of ASTM B 209 or B 308 for alloy 6061 T6.
- C. Members supporting aluminum grating shall be aluminum shapes as shown on the Drawings.

2.03 ALUMINUM FASTENINGS

- A. Connections of aluminum to aluminum shall be aluminum. Bolts shall meet all requirements of ASTM B 3160-75 for alloy 2024-T4. Bolts shall have an anodic coating having a minimum thickness of .0002 inches. Nuts shall be 6061-T6. Washers shall be Alclad 2024-T4.

2.04 STAINLESS STEEL FASTENINGS

- A. Connections of aluminum support members to concrete shall be stainless steel anchor or expansion bolts of AISI Type 316.

2.05 ALUMINUM PLATE

- A. Checkered floor plates shall be aluminum with raised diamond pattern on the upper surface. Aluminum plate shall be 1/8" thick.
- B. Aluminum surfaces in contact with concrete or dissimilar metals shall be protected with a coat of bituminous paint.

PART 3 - EXECUTION

3.01 FIELD INSPECTION

- A. Prior to beginning installation, a thorough investigation shall be made of the structure to receive the system to insure that the system can be installed to the indicated alignment. Installation shall not be started until that surface is satisfactory.

3.02 INSTALLATION

- A. The aluminum grating system shall be installed as indicated on the Drawings and Shop Drawings.

END OF SECTION

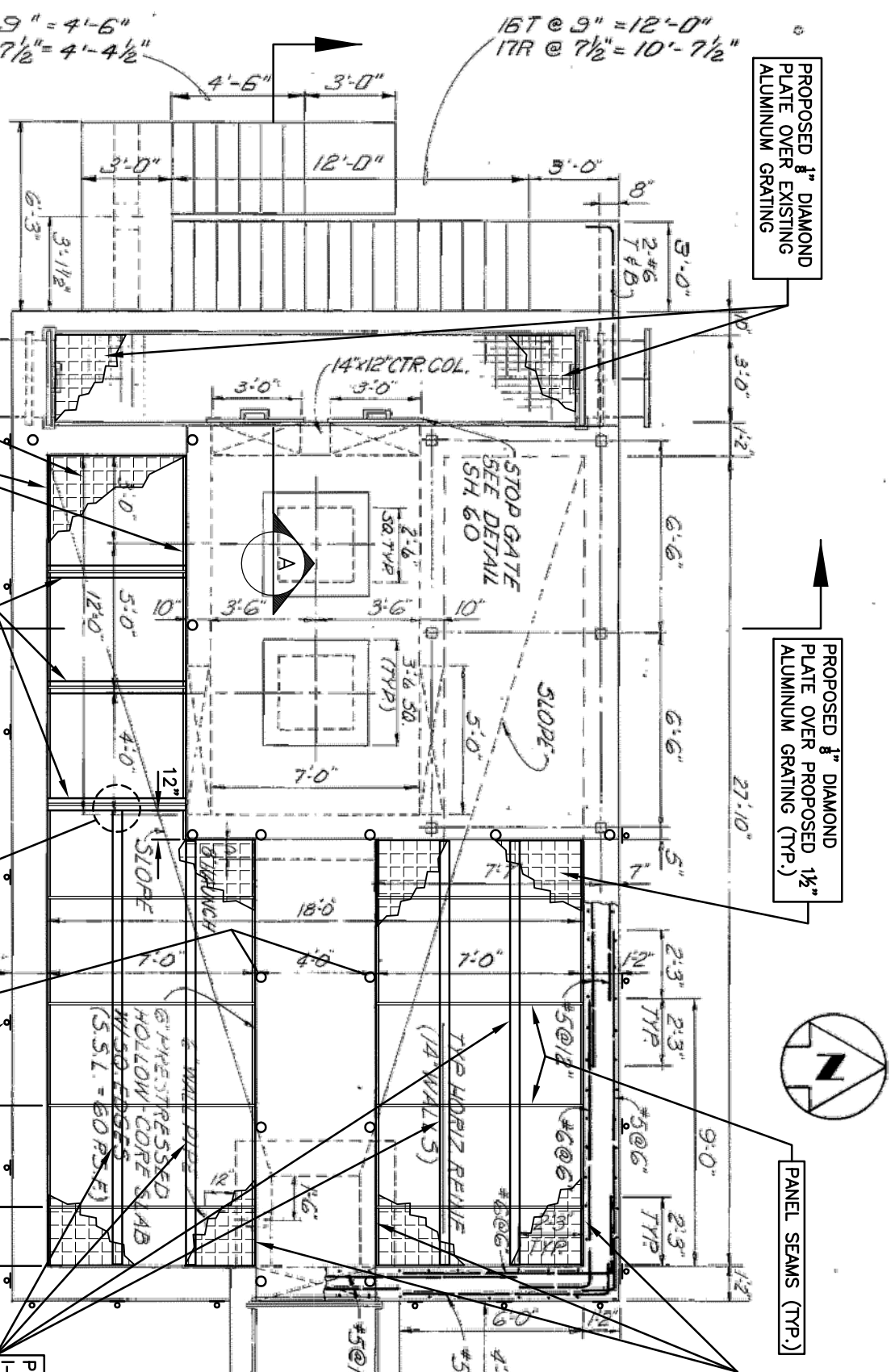

PLAN
SCALE: 3/16" = 1'-0"

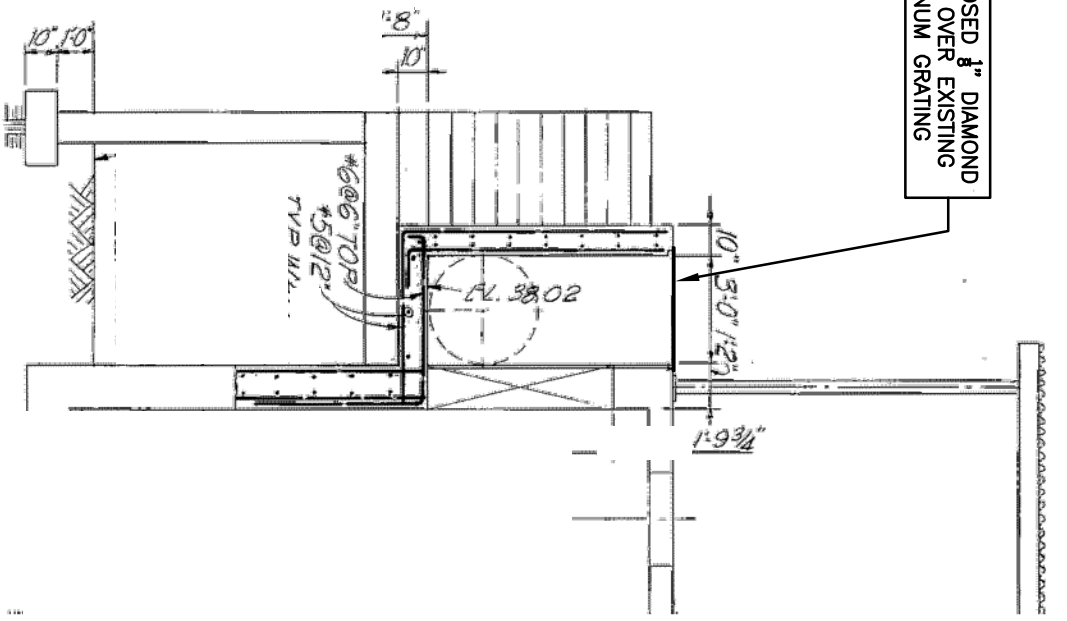

SECTION A
SCALE: 3/16" = 1'-0"

- PROPOSED 1/8" DIAMOND PLATE OVER EXISTING ALUMINUM GRATING
- PROPOSED 1/2" DIAMOND PLATE OVER PROPOSED 1/2" ALUMINUM GRATING (TYP.)
- PROPOSED 2"x2"x1/4" ALUMINUM ANGLE TO SUPPORT PROPOSED 1/2" DIAMOND PLATE
- PROPOSED 8"x7.02 ALUMINUM I-BEAM (3) TO SUPPORT PROPOSED 1/2" ALUMINUM GRATING AND 1/8" DIAMOND PLATE TO BE LOCATED AT PANEL SEAMS. MAXIMUM SPACING 4 FT.
- PROPOSED 1/8" DIAMOND PLATE OVER PROPOSED 1/2" ALUMINUM GRATING (TYP.)
- PROPOSED 2"x2"x1/4" ALUMINUM ANGLE TO SUPPORT PROPOSED 1/2" DIAMOND PLATE
- PROPOSED 8"x7.02 ALUMINUM I-BEAM (4) TO SUPPORT PROPOSED 1/2" ALUMINUM GRATING AND 1/8" DIAMOND PLATE
- INTERNAL PANEL SECTION MAX. WIDTH 4FT (TYP.)
- PROPOSED SIDE MOUNTED ALUMINUM HANDRAIL (TYP.)
- END PANEL SECTION MAX. WIDTH 2FT (TYP.)
- REMOVE EXISTING HANDRAIL AND MOUNTING HARDWARE ALL LOCATIONS SHOWN. CONTRACTOR TO PATCH OR REFINISH CONCRETE AS NECESSARY (TYP.)
- SEE I-BEAM CONNECTION DETAIL SHEET 2

NOTES

1. BASIN COVERS TO BE 1-1/2" ALUMINUM GRATING COVERED WITH 1/8" ALUMINUM DIAMOND PLATE. SEE DETAILS SHEET 4.
2. EACH COVER DIMENSION SHALL MATCH A CORRESPONDING EXISTING ALUMINUM GRATING SECTION. CONTRACTOR SHALL FIELD VERIFY EXISTING GRATING PANEL DIMENSIONS PRIOR TO COVER FABRICATION, WHERE APPLICABLE.
3. ALL PANELS SHALL HAVE MIN. OF 2 (TWO) HANDLES AT EACH END OF PANEL OVER A GRATE SPACING TO FACILITATE REMOVAL OF GRATE/PANEL ASSEMBLY. SEE DETAIL ON SHEET 4.
4. SEE DETAIL ON SHEET 4 FOR TYPICAL PANEL ATTACHMENT.
5. CONTRACTOR SHALL INSPECT AND REPLACE EXISTING DAMAGED GRATING PRIOR TO INSTALLING COVERS.
6. CONTRACTOR SHALL FURNISH AND INSTALL NEW GRATING AND ADJUST COVERS WHERE REQUIRED TO ACCOMMODATE NEW ACCESS PANELS.
7. ALL ALUMINUM TO BE GRADE 6061. ALL HARDWARE TO BE 316 STAINLESS STEEL.
8. CONTRACTOR TO FIELD VERIFY ALL PIPE PENETRATIONS AND HANDRAIL LOCATIONS FOR COVER INSTALLATION.

NO.	BY	REVISIONS

QUENTIN I. HAMPTON ASSOCIATES, INC.
CONSULTING ENGINEERS
FLORIDA CERTIFICATE OF AUTHORIZATION NUMBER: 626
P.O. DRAWER 290247 PORT ORANGE, FL 32129-0247 386 761-6810

UTILITIES COMMISSION
NEW SMYRNA BEACH

CHLORINE CONTACT BASIN AND FILTER FEED FLUME COVERS

CHLORINE CONTACT BASIN PLAN AND SECTION

MARK A. HAMPTON, P.E. 27391
BRADLEY T. BLAS, P.E. 47130
DAVID A. KING, P.E. 50609
ANDREW M. GIANNINI, P.E. 46601
KENNETH A. LEE, P.E. 71501

DESIGNED	KAL	DATE	11-10	SCALE
DRAWN	RPS	DATE	11-10	AS SHOWN
CHECKED	---	DATE	---	---
APPROVED	---	DATE	---	---

SHEET NO. 1 OF 4

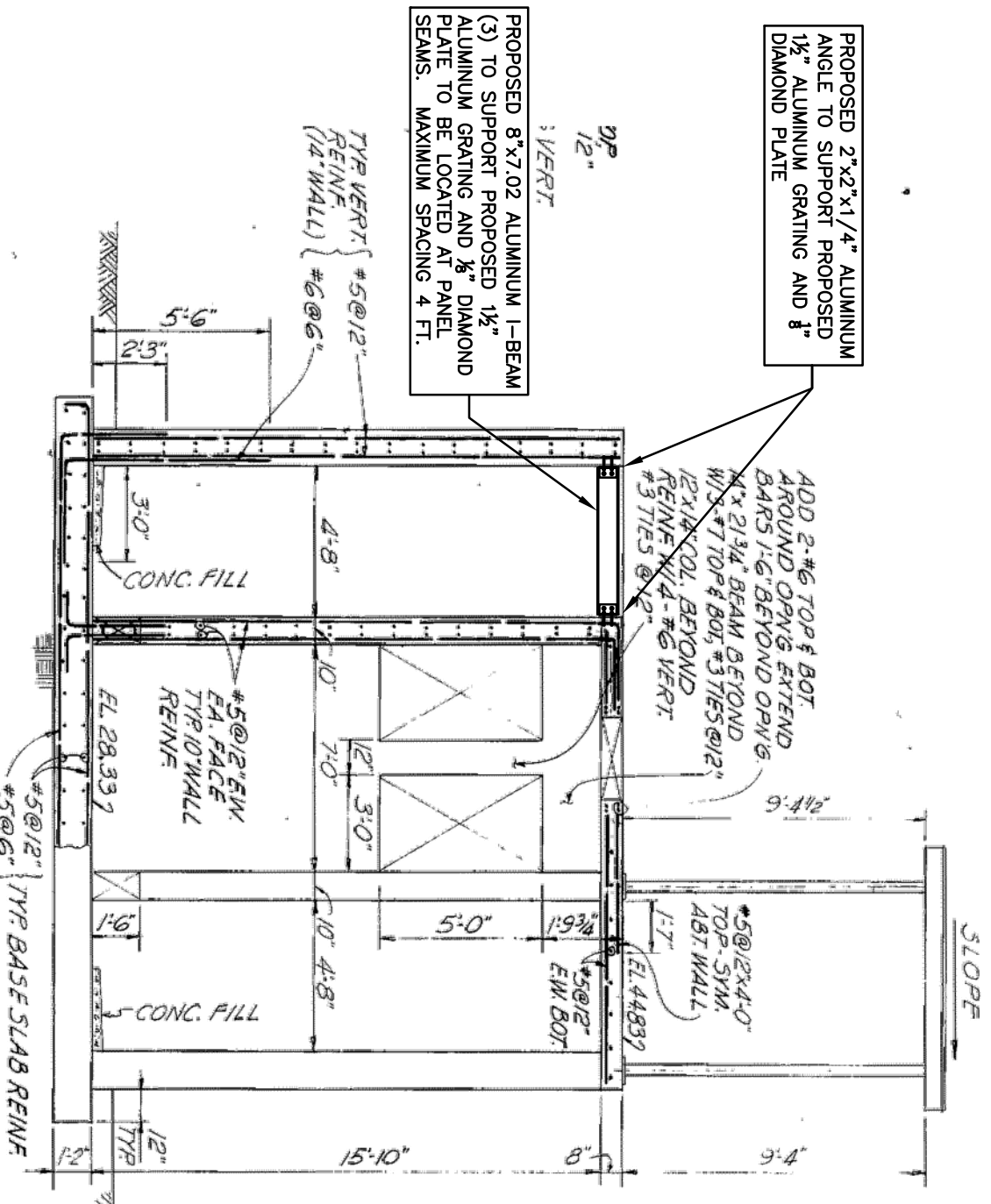

PROPOSED 8" X 7.02 ALUMINUM I-BEAM (3) TO SUPPORT PROPOSED 1 1/2" ALUMINUM GRATING AND 3/8" DIAMOND PLATE TO BE LOCATED AT PANEL SEAMS. MAXIMUM SPACING 4 FT.

PROPOSED 2" X 2" X 1/4" ALUMINUM ANGLE TO SUPPORT PROPOSED 1 1/2" ALUMINUM GRATING AND 3/8" DIAMOND PLATE

ADD 2-#6 TOP & BOT AROUND OPNG EXTEND BARS 1'-6" BEYOND OPNG.
4" X 2 1/4" BEAM BEYOND W/S -#7 TOP & BOT, #3 TIES @ 12"
12" X 18" COL. BEYOND REINFE #4-#6 VERT #3 TIES @ 12"

SECTION B
SCALE: 3/16" = 1'-0"

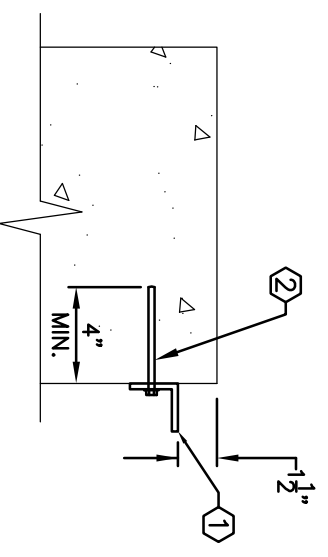

TYPICAL ALUMINUM ANGLE ATTACHMENT DETAIL
SCALE: 3" = 1'-0"

- ① 2" x 2" x 1/4" ALUMINUM ANGLE
- ② 3/4" 316 SS THREADED ROD WITH HILTI EPOXY EMBEDS @ 16" O.C. (TYPICAL)

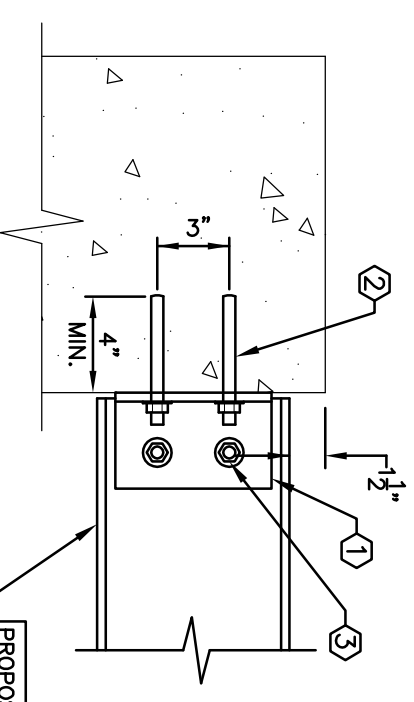

TYPICAL I-BEAM BRACKET ATTACHMENT DETAIL
SCALE: 3" = 1'-0"

- ① (2) 4" x 4" x 3/8" ALUMINUM ANGLE BRACKETS MINIMUM 6 1/2" LONG BOLTED TO I-BEAM (ONE EACH SIDE)
- ② (4) 3/4" 316 SS THREADED ROD WITH HILTI EPOXY EMBEDS. (TWO EACH SIDE)
- ③ (2) 3/4" 316 SS BOLTS

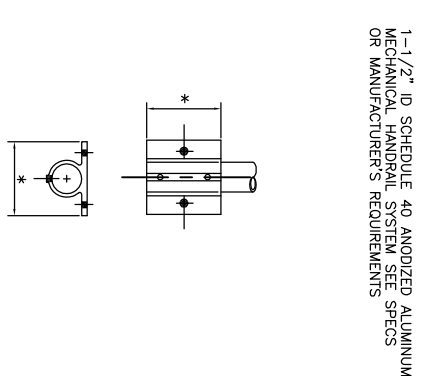

HANDRAIL SIDE MOUNT CONNECTION
* - DIMENSIONS PER MANUFACTURER

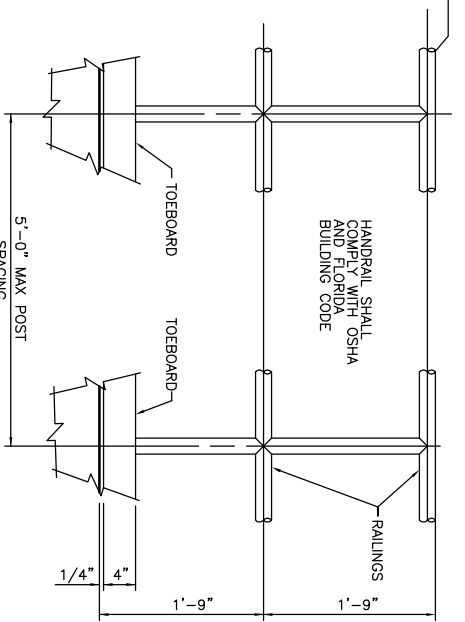

- HANDRAIL NOTES:
1. ALUMINUM SHAPES IN CONTACT WITH CONCRETE MUST BE SEPARATED BY A 1/32" NEOPRENE GASKET OR ANY CASE WHERE TWO DIFFERENT METALS ARE TO BE IN CONTACT, A NEOPRENE GASKET MUST BE PROVIDED.
 2. HANDRAILS, POSTS, BRACKETS AND MOUNTINGS SHALL MEET THE FLORIDA BUILDING CODE AND OCCUPATIONAL SAFETY AND HEALTH ADMINISTRATION (OSHA) LOADING REQUIREMENTS.
 3. TOP OF ALL HANDRAILS SHOULD BE 42" HIGH ABOVE THE FINISH FLOOR OR WALKWAY. THE CLEAR DISTANCE BETWEEN THE TOP AND INTERMEDIATE RAILS MEASURED AT RIGHT ANGLES TO THE RAILS SHALL NOT EXCEED 21".

HANDRAIL DETAILS
SCALE: 3" = 1'-0"

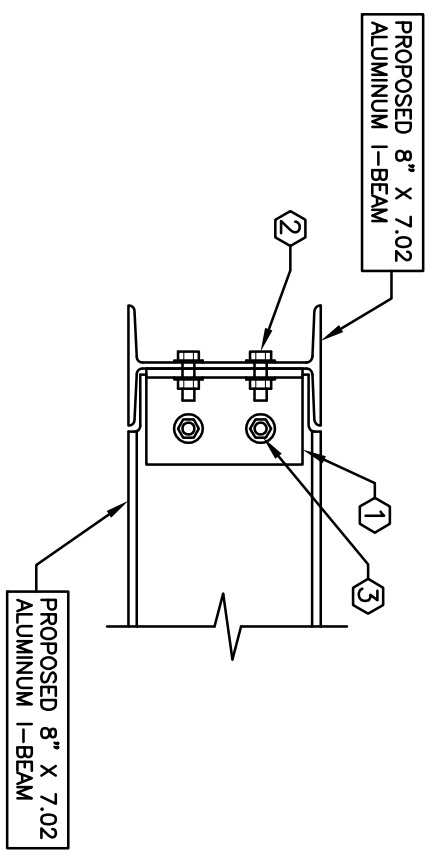

I-BEAM CONNECTION DETAIL
SCALE: 3" = 1'-0"

- ① (2) 4" x 4" x 3/8" ALUMINUM ANGLE BRACKETS MINIMUM 6 1/2" LONG BOLTED TO I-BEAM (ONE EACH SIDE)
- ② (4) 3/4" 316 SS BOLTS (TWO EACH SIDE)
- ③ (2) 3/4" 316 SS BOLTS

NO.	BY	DATE	REVISIONS

QUENTIN L. HAMPTON ASSOCIATES, INC.
CONSULTING ENGINEER &
FLORIDA CERTIFICATE OF AUTHORIZATION NUMBER: 626
P.O. DRAWER 290247 PORT ORANGE, FL 32129-0247 386 761-6810

UTILITIES COMMISSION NEW SMYRNA BEACH

CHLORINE CONTACT BASIN AND FILTER FEED FLUME COVERS

RECARB BASIN SECTIONS

MARK A. HAMPTON, P.E. 27391
BRADLEY T. BLAS, P.E. 47130
DAVID A. KING, P.E. 50609
ANDREW M. GIANNINI, P.E. 46601
KEVIN A. LEE, P.E. 71501

DESIGNED	KAL	DATE	11-10	SCALE	AS SHOWN
DRAWN	RPS	DATE	11-10	SHEET NO.	2
CHECKED	---	DATE	---	OF	4
APPROVED	---	DATE	---		

REPLACE ALL ALUMINUM GRATING WITH
1-3/4" ALUMINUM GRATING AND
INSTALL 1/2" DIAMOND PLATE (TYPICAL)

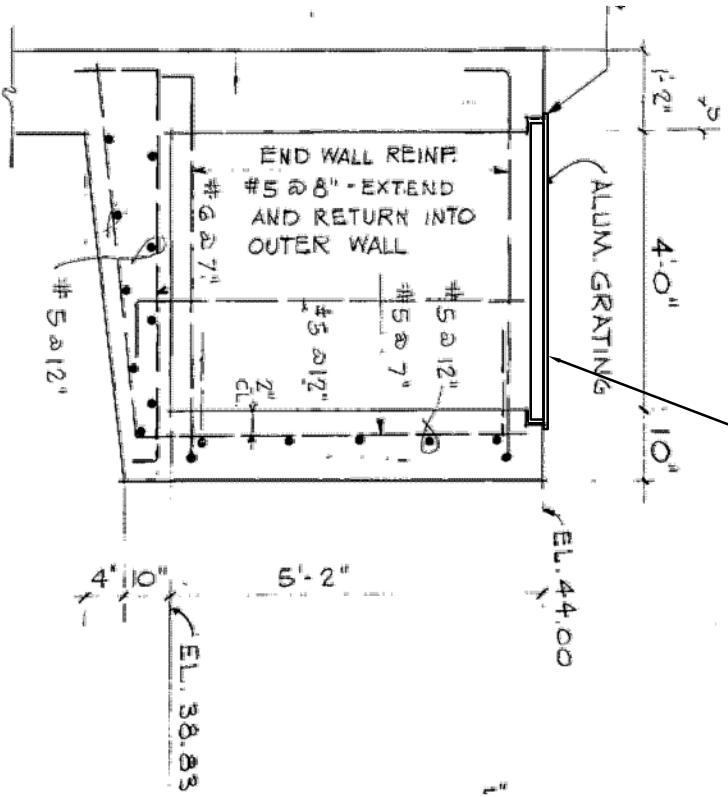

SECTION C
SCALE: 3/8" = 1'-0"

SEE NOTES SHEET 1
AND DETAILS SHEET 4

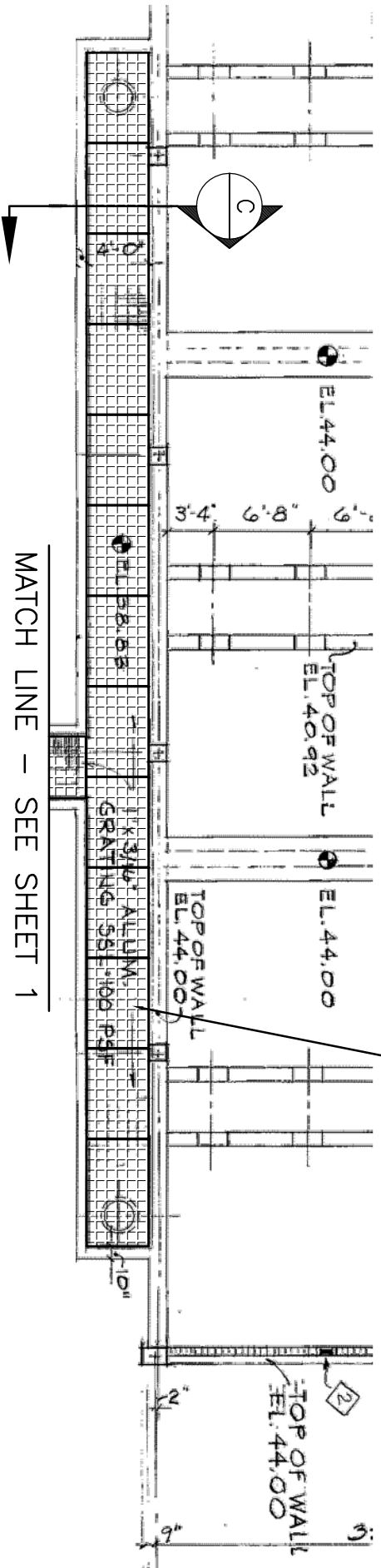

PROPOSED PLAN
SCALE: 3/32" = 1'-0"

REPLACE ALL ALUMINUM GRATING WITH
1-3/4" ALUMINUM GRATING AND
INSTALL 1/2" DIAMOND PLATE (TYPICAL)

NO.	BY	DATE	REVISIONS

QUENTIN L. HAMPTON ASSOCIATES, INC.
CONSULTING ENGINEERS
FLORIDA CERTIFICATE OF AUTHORIZATION NUMBER: 626
P.O. DRAWER 290247 PORT ORANGE, FL 32129-0247 386 761-6810

UTILITIES
COMMISSION
NEW SMYRNA
BEACH

CHLORINE CONTACT
BASIN AND FILTER FEED
FLUME COVERS

FILTER TROUGH PLAN

MARK A. HAMPTON, P.E. 27391
BRADLEY T. BLAIS, P.E. 47130
DAVID A. KING, P.E. 50609
ANDREW M. GIANNINI, P.E. 48601
KEVIN A. LEE, P.E. 71501

DESIGNED	KAL	DATE	11-10	SCALE	SHEET NO.
DRAWN	RPS	DATE	11-10	AS SHOWN	3
CHECKED	---	DATE		JOB NO.	
APPROVED	---	DATE			

OF 4

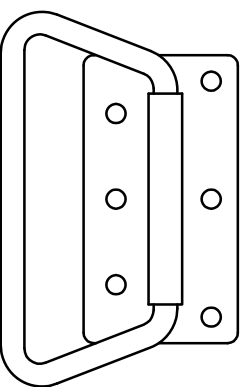

TYPICAL STAINLESS STEEL FLUSH MOUNT COVER HANDLE

MOUNT ON ALUMINIUM DIAMOND PLATE COVER USING 316 STAINLESS STEEL FASTENERS.

NOT TO SCALE

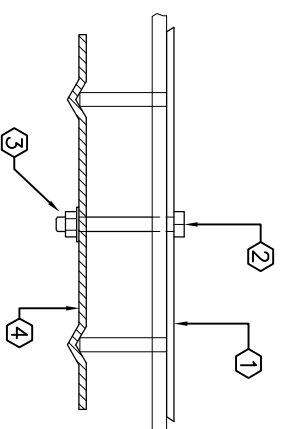

TYPICAL COVER ATTACHMENT

NOT TO SCALE

- ① 1/8" ALUMINIUM DIAMOND PLATE COVER OVER EXISTING ALUMINIUM GRATING.
- ② 5/16" 316 S.S. FLAT HEAD HEX BOLT
- ③ 5/16" 316 S.S. NUT AND LOCK WASHER
- ④ 1/8" x 1-1/2" ALUMINIUM FLAT BAR LENGTH TO SPAN MAJOR GRATE SUPPORT PLUS 1/2" OVERLAP EACH SIDE.

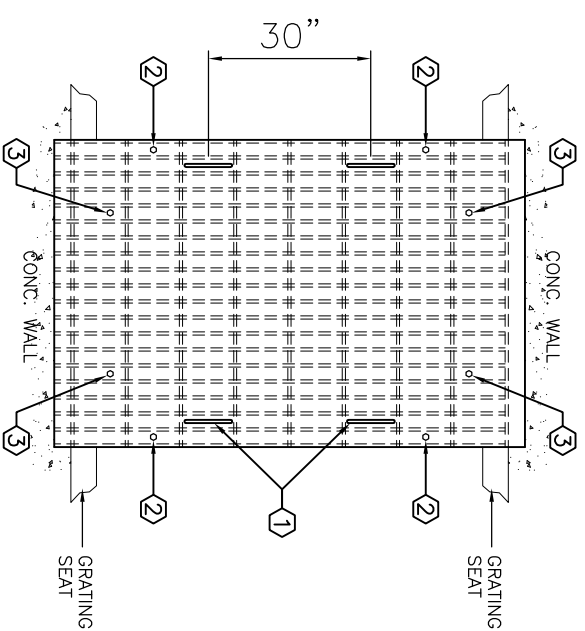

COVER PLATE DETAILS

NOT TO SCALE

- ① TYPICAL HANDLE 6"± FROM EACH SIDE. TYPICAL OF 2 AT EACH SIDE OF COVER.
- ② COVER ATTACHMENT - LONG SIDE SEE TYPICAL ATTACHMENT DETAIL THIS SHEET SPACING - 2'-0" O.C. MAX. EACH SIDE
- ③ COVER ATTACHMENT - SHORT SIDE SEE TYPICAL ATTACHMENT DETAIL THIS SHEET SPACING - MIN. OF 2 ATTACHMENT POINTS EQUALLY SPACED AT EACH END OF COVER.

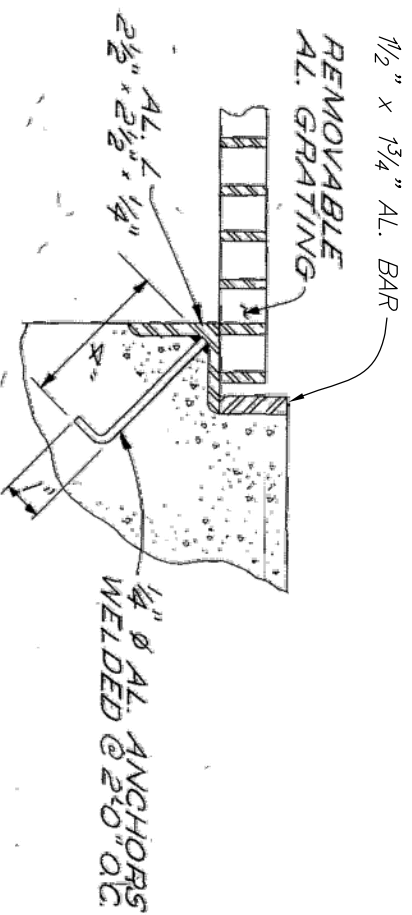

EXISTING TYP. CURB ANGLE - DETAIL

NOT TO SCALE

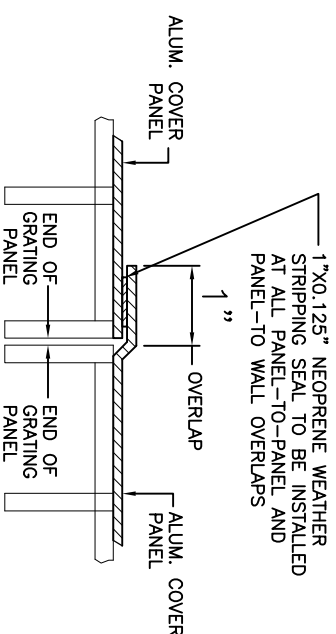

TYPICAL OVERLAP BETWEEN PANELS

NOT TO SCALE

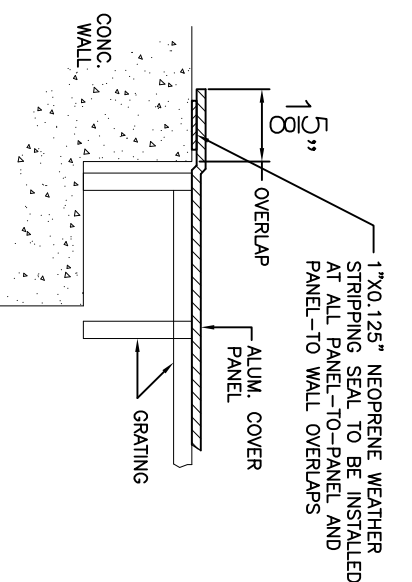

TYPICAL OVERLAP AT GRATING SEAT

NOT TO SCALE

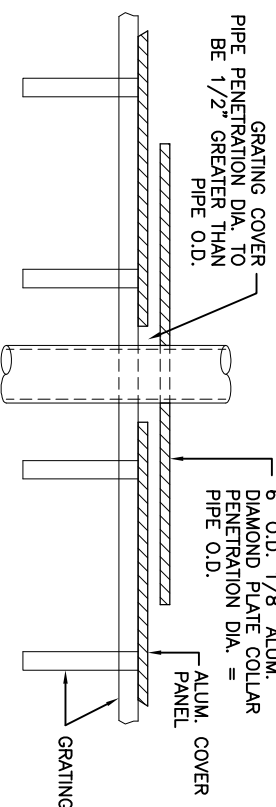

TYPICAL PIPE PENETRATION COLLAR

NOT TO SCALE

NOTE:
CONTRACTOR TO FIELD VERIFY ALL PIPE PENETRATIONS IN FIELD.

NO.	BY	DATE	REVISIONS

QUENTIN L. HAMPTON ASSOCIATES, INC.
CONSULTING ENGINEERS
 FLORIDA CERTIFICATE OF AUTHORIZATION NUMBER: 626
 P.O. DRAWER 290247 PORT ORANGE, FL. 32129-0247 386 761-6810

UTILITIES COMMISSION NEW SMYRNA BEACH

CHLORINE CONTACT BASIN AND FILTER FEED FLUME COVERS

DETAILS

MARK A. HAMPTON, P.E. 27391
 BRADLEY T. BLAS, P.E. 47130
 DAVID A. KING, P.E. 50609
 ANDREW M. GIANNINI, P.E. 46601
 KEVIN A. LEE, P.E. 71501

DESIGNED	KAL	DATE	11-10	SCALE	AS SHOWN
DRAWN	RPS	DATE	11-10	JOB NO.	
CHECKED	---	DATE			
APPROVED	---	DATE			

UTILITIES COMMISSION
City of New Smyrna Beach, Florida

Bid No. 04-11

BID FORM

**LABOR FOR FABRICATION OF ALL MATERIAL REQUIRED TO COMPLETE
TURNKEY PROJECT:**

\$ _____

MATERIALS REQUIRED FOR FABRICATION:

\$ _____

FLAT RATE PRICING FOR INSTALLATION:

\$ _____

PERMIT FEE:

\$ _____

The undersigned hereby declares that the following list states any and all variations from, and exceptions to, the requirements of the instructions and specifications.

These prices are valid for orders placed within Sixty (60) days from date of bid award.

Submitted By: _____ Company

_____ Name & Title

_____ Signature

_____ Telephone No. _____ Facsimile No.